

MODEL: OT150-12

Product Code:302010005-00198



Plane Chart:

Unit:(mm) Terminal type:(B5)

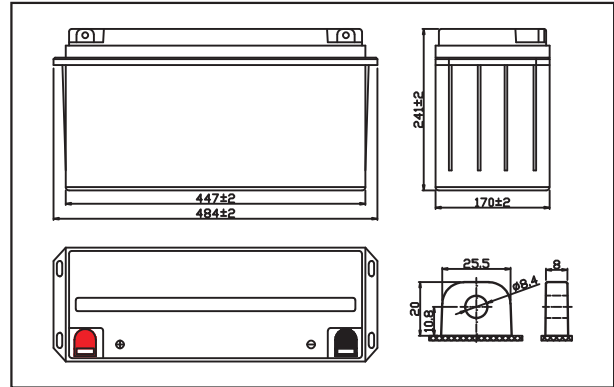

Characteristic:

- 100% testing before out of factory, stable and reliable quality is guaranteed.
- Professional alloy formula and advanced manufacturing techniques.
- Completely sealed and maintenance free, low self-discharge.
- Good charge-discharge acceptability.
- Cyclic application: deep cycle charge-discharge for more than 260 times.
- Floating application: for 5-7 years.

Application:

- Anti-theft system
- Radio transceiver
- Power system
- Railroad engine and railway communication
- Emergency lighting and lamps
- Electric tools
- Electronic instruments and other backup power
- Medical facilities
- UPS for banking system
- Computer backup power
- Marine system
- UPS for fire fighting system
- Toys

Parts:

Cover	Container Bottom	Terminal	Positive Plate	Negative Plate	Separator	Electrolyte	Safety Valve	Seal Glue
ABS UL94V-0	ABS [UL94V-0]	Copper	PbO ₂	Pb	AGM	dilute sulphuric acid	Rubber	Epoxy Resin

Packing

Date	Battery Packing	Inner Packing	Outer Packing
Printing	Polybag	Paper Box	Carton Packing
Branded	Shrink		
Carton Sealing		Accessories	
Packing Strap		Bolts&nuts	Mini Charger
Shrink		With	Optional

Parameter Chart:

Volts		12V	
Capacity(25°C)		10 hours rate (15A)	150Ah
Discharge Current Testing (25°C)		1 hours rate (82.5A)	83min
		3 hours rate(37.5A)	113Ah
Internal Resistance		Full Charged Battery 25°C	3.4mΩ
Capacity Affected By Temperature (20 hours rate)		40°C	104%
		25°C	100%
		0°C	83%
		-15°C	65%
Residual Capacity (25°C)		Capacity After 3 Months Storage	91%
		Capacity After 6 Months Storage	82%
		Capacity After 12 Months Storage	65%
Charge (Constant Voltage)	Cycle (25°C)	Initial Charging Current Less Than 45A Voltage 14.5-14.9V	
	Floate (25°C)	Charge Voltage 13.6-13.8V	
Weight (Approx)		42.5Kg	

★The above are average and data obtained from the first 3 charge/discharge cycles. These are not minimum values.

Discharge Curve

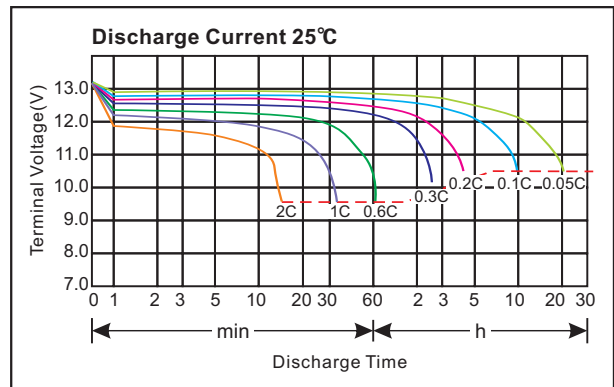
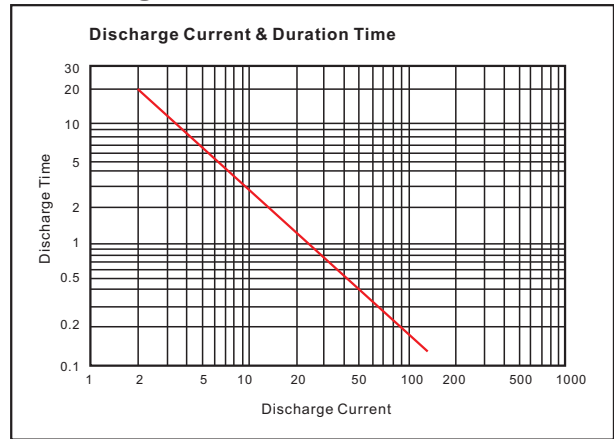



Constant Current Discharge Characteristics(A,25°C)										
F.V/Time	15min	15min	60min	2h	3h	4h	5h	8h	10h	20h
9.60V	267.3	158.4	96.5	54.3	39.2	31.1	27.3	18.1	15.2	7.8
10.2V	256.4	152.5	92.7	53.5	38.6	30.7	26.9	17.9	15.1	7.8
10.5V	251.5	148.5	90.8	53.0	38.2	30.5	26.6	17.8	15.0	7.8
10.8V	243.5	144.5	88.0	52.4	37.8	29.5	26.4	17.8	15.0	7.7

Constant Current Discharge Characteristics(Watt,25°C)										
F.V/Time	15min	30min	60min	2h	3h	4h	5h	8h	10h	20h
9.60V	2935.4	1777.1	1100.9	628.7	461.3	365.3	322.7	214.8	181.2	93.9
10.2V	2815.6	1710.7	1056.3	618.8	454.4	360.4	318.8	212.9	179.2	93.9
10.5V	2760.1	1666.2	1034.6	612.8	449.5	358.4	314.8	211.9	178.2	93.2
10.8V	2674.0	1621.6	1002.9	606.9	445.5	347.5	312.8	210.9	177.2	92.7

Loading Info

Master Carton			Pallet			20 GP	
Pcs/Ctn	Size (mm)	N W (.kg)	Size (mm)	Total CTNS	N W (T)	Pallet Qty	Battery Qty(pcs)
1 PCS	575*127*365	42.5	120*82	36	1.64	7	476
			105*82	32	1.46	7	

